

# COMMERCIAL HEAT TRACE

## CET-GF Commercial Heat Trace Electronic Thermostat w/GFI

- 30 Amp Double-Pole, Mechanical Relay
- 120 to 277 Vac Operation
- On/Off Control with 10° Deadband Programmable in Two Degree Increments.
- LED Indication for Power, Alarm and Load
- Large LED Display
- Programmable High & Low Temperature Alarms
- Form C dry contact alarm for remote indication of alarm status
- NEMA 4X Enclosure
- Integral Pipe Stand
- Optional Wall Mount
- 100 Ohm Platinum RTD -Included
- Enclosure Serves as Heating Cable, A/C Power & Sensor Connection
- Works with CPR, CPM and CZH Cable
- RoHS Compliant

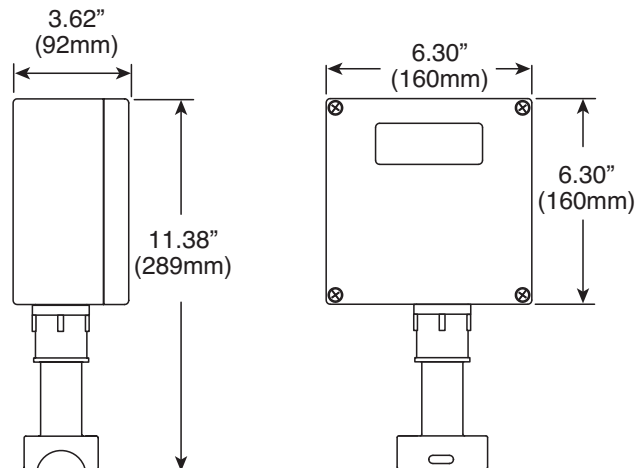

### Description

The CET-GF electronic thermostat with ground fault is a temperature control and power connection kit.

It is used for freeze protection or process temperature maintenance of pipes protected by heat tracing products. This thermostat can be used with CPR, CPM or CZH heating cables in Ordinary area locations.

This unit is designed to provide local temperature control for pipe freeze protection, flow maintenance, freezer frost heave, floor heating and snow melting applications and will switch 30 amperes of current.

The CET-GF provides easy programming of the temperature set point, high and low temperature alarms, the deadband, the temperature units and the alarm state through the front panel push

buttons. LED lights are provided for indication of power to the unit, heater power on (load) and alarm status. A Form C dry contact alarm is included for wiring to your building management system to indicate alarm status. This alarm may be set to open or close on all alarm conditions including loss of power, high or low temperature alarm and RTD failure. The minimum operating ambient temperature is -35°F (-37°C). This unit has programmable high and low temperature alarm set points from 20°F (-6°C) to 230°F (110°C).

A 100 Ohm platinum RTD is provided with a 3 foot (1 M) lead resulting in flexible mounting options for the user.

HEAT TRACING  
PRODUCTS

# COMMERCIAL HEAT TRACE

## CET-GF Commercial Heat Trace Electronic Thermostat w/GFI (cont'd.)

### Features

- Small Enclosure. The 6.25 inch by 6.25 inch enclosure houses the temperature control and monitoring unit along with terminals for connecting instrument power, heating cable and RTD.
- 100 Ohm platinum RTD which can be pipe mounted or can be used to sense ambient air temperature.
- Pipe stand-off mount for direct pipe mounting.
- Integral wiring. The wiring of the heating cable, alarm, AC power line and the RTD sensor are all accomplished within the enclosure. This feature reduces both labor and material costs by eliminating the need for an additional heat trace power connection kit as well as the time for the additional wiring.

PCN	Model
514407	CET-GF

### Accessories

PCN	Model
514415	CET-WB Wall Mount Kit
514263	RTD-50 Extension Wire (50 ft/15m)

### Applications

- Freeze Protection of Piping
- Flow Maintenance
- Freezer Frost Heave
- Floor Heating

### Environments

- Ordinary Areas

### Sensors

- 100 OHM PT RTD
- Probe Length = 4" (10.2 cm)
- Probe Diameter = 1/4" (6.35 mm)
- Leadwire Length = 3ft (1 M)\*

\* The maximum allowable length of the RTD wire is 50ft (15m) in order to remain cULus compliant.

### Specifications

Operating Voltage	120 to 277 VAC, 50/60 Hz, Single Phase common supply for controller and heat tracing circuit		
Operating Temperature - Ordinary Areas	-35°F to 140°F (-37s°C to 60°C)		
Input	100 Ohm platinum RTD		
Output	30A Double-pole, mechanical		
Alarms	High temp to 302°F (150°C) Low temp to 20°F (-7°C) RTD Failure Red LED alarm status indicator on front panel		
Alarm Relay:	Form C: 2A @ 277Vac, 2A @ 48Vdc		
Alarm Function:	<u>Mode</u>	<u>Default</u>	<u>Optional</u>
	Normal Operation	Closed	Open
	Alarm Condition	Open	Closed
	Power Off	Open	Open
Deadband	2°F (or °C) to 10°F (or °C), programmable		
Set Points	32°F to 200°F programmable (0°C to 93°C)		
Units of Temperature	°F or °C, selectable		
Control Mode	On/Off control		
Memory	Nonvolatile, restored after power loss		